

Microbulk Stationary Pallet Tanks for LOX, LIN, LAR

Flow Diagram

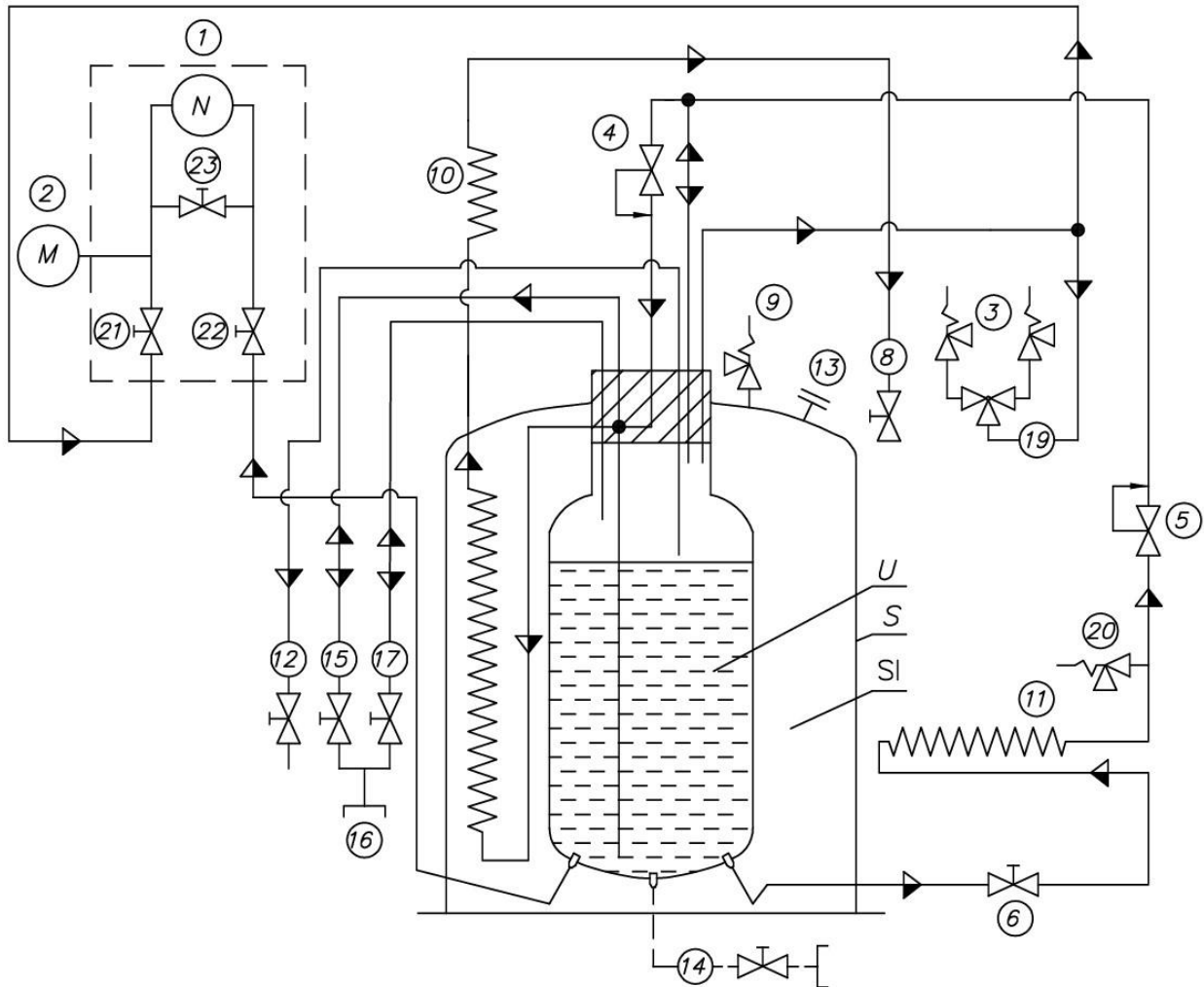

U	Inner vessel	11	Pressure build-up vaporizer
S	Outer jacket	12	Overflow
SI	Multilayer insulation	13	Vacuum lock
1	Liquid level indicator	14	Liquid gas pump supply (optional)
2	Manometer	15	Bottom liquid inlet - outlet
3	Inner vessel safety valves	16	Filling connection
4	Economizer	17	Top liquid inlet – gas outlet
5	Pressure regulator	19	Three way valve
6	Pressure build-up valve	20	Safety valve
8	Gas outlet	21	Liquid level (-)
9	Safety disc	22	Liquid level (+)
10	Product vaporizer	23	Equalizer valve