

Multipurpose Pallet Tank for LOX, LIN, LAR, LIC(LCO₂), LN₂O, LNG

Flow Diagram

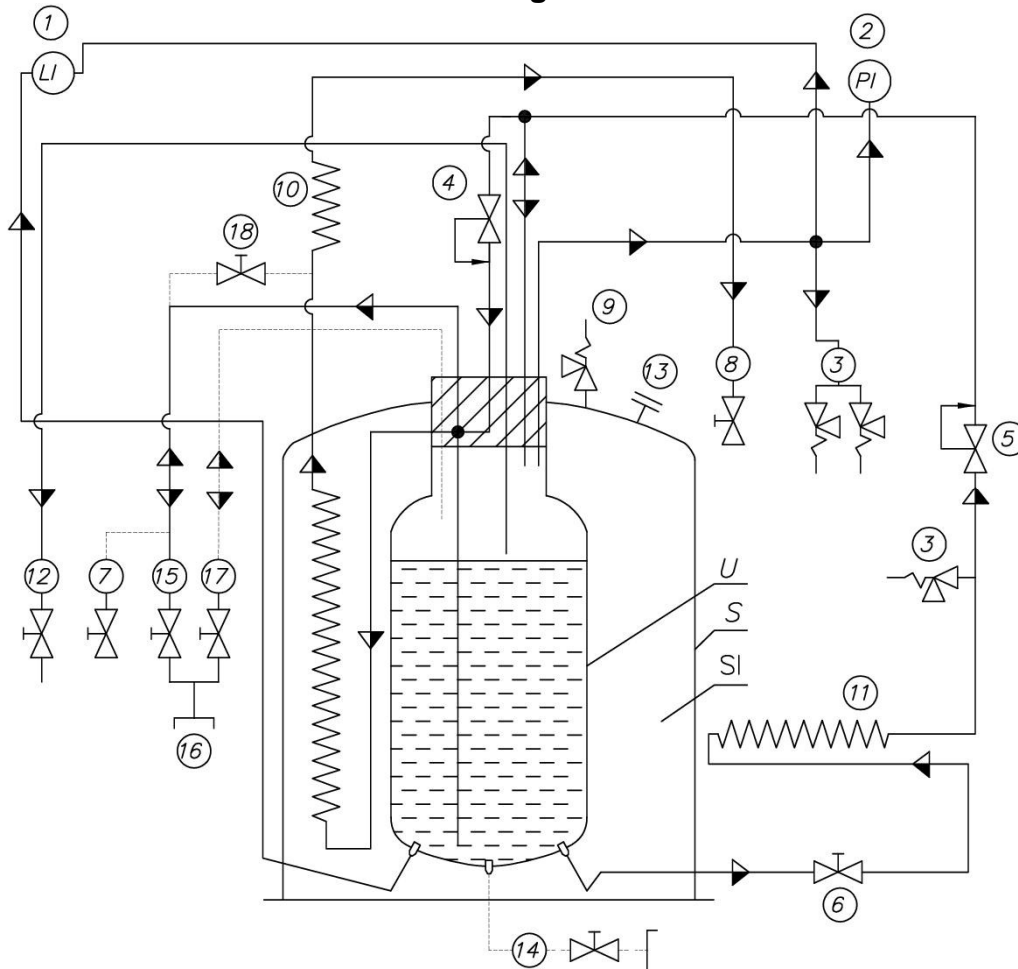

- | | | | |
|-----------|------------------------------|-----------|--|
| U | Inner vessel | 9 | Safety disc |
| S | Outer jacket | 10 | Product vaporizer |
| SI | Multilayer insulation | 11 | Pressure build-up vaporizer |
| 1 | Liquid level | 12 | Overflow |
| 2 | Manometer | 13 | Vacuum lock |
| 3 | Safety valves | 14 | Liquid gas pump supply (optional) |
| 4 | Economizer | 15 | Bottom liquid inlet-outlet |
| 5 | Pressure regulator | 16 | Filling connection |
| 6 | Pressure build-up valve | 17 | Top liquid inlet (optional) |
| 7 | Liquid withdrawal (optional) | 18 | Liquid to product vaporizer – high output (optional) |
| 8 | Gas outlet | | |