

Multipurpose Pallet Tanks for LOX, LIN, LAR, LIC(LCO₂), LN₂O, LNG

Flow Diagram

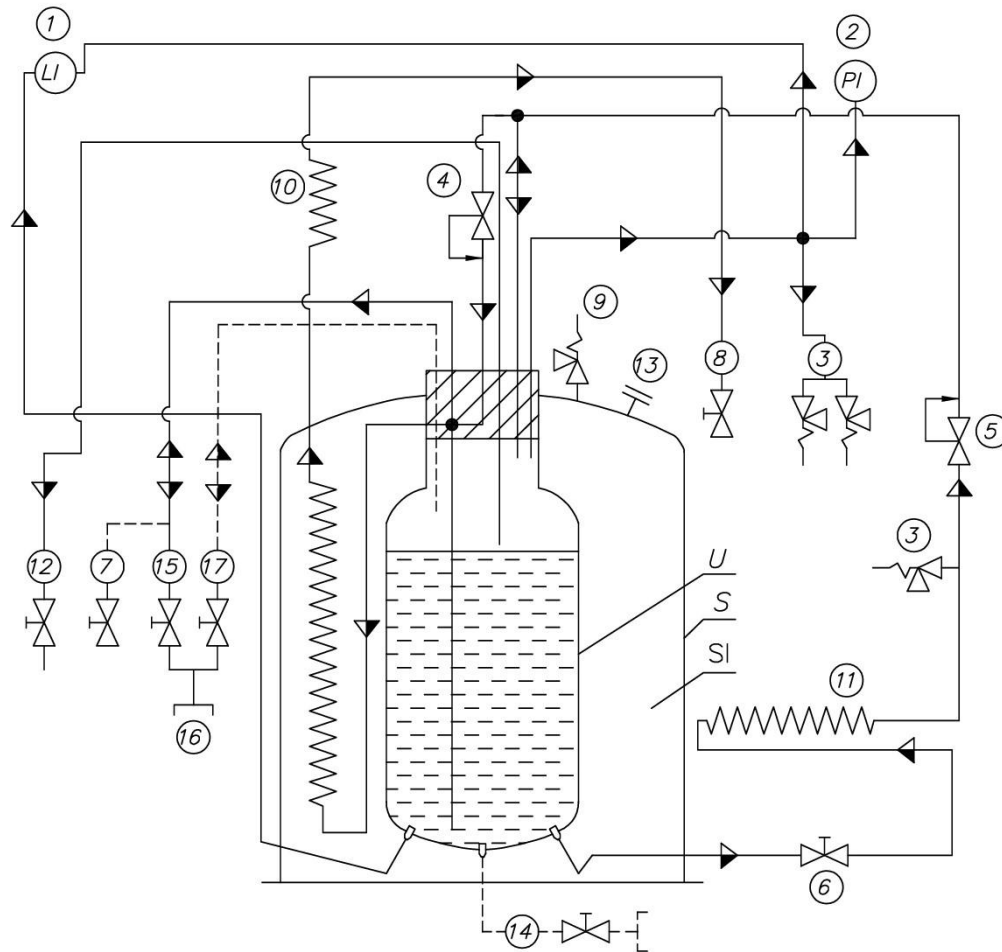

U	Inner vessel	8	Gas outlet
S	Outer jacket	9	Safety disc
SI	Multilayer insulation	10	Product vaporizer
1	Liquid level	11	Pressure build-up vaporizer
2	Manometer	12	Overflow
3	Safety valves	13	Vacuum lock
4	Economizer	14	Liquid gas pump supply (optional)
5	Pressure regulator	15	Bottom liquid inlet-outlet
6	Pressure build-up valve	16	Filling connection
7	Liquid withdrawal (optional)	17	Top liquid inlet (optional)